



Single Inlet Centrifugal Fans MSVA Series

- Single Inlet MSVA fans compact structure benefits space saving for various cooling and ventilation applications.
- Low noise, resistant housing structure, high pressure.
- Casing is made of aluminium.
- Impeller is forward curved and made of galvanized sheet iron.
- Class B.
- Air flow up to 700m³/h.
- Standard: EN 60335-1 EN 60335-2-80



Perfect for industrial and commercial applications, especially local cooling applications and heating systems. Machines cooling, boilers, yacht air conditioning, DC motor cooling, plastic machines, sock machines, electric board cooling, laboratories, residential and industrial areas etc.

Technical Characteristics MSVA Series

Type	Impeller	Power (W)	RPM	Air Flow (m ³ /h)	Weight (Kg)	Inlet	Outlet	Price
MSVA1	140 X 60	137	2.265	485	3	Πλέγμα	Φλάντζα	€ 130,00
MSVA2	140 X 60	137	2.265	485	3	Πλέγμα	Λαιμός 100mm	€ 130,00
MSVA3	140 X 60	137	2.265	485	3	Λαιμός 100mm	Λαιμός 100mm	€ 134,00
MSVAD	140 X 60	137	2.265	485	3	Τάμπερ	Φλάντζα	€ 130,00
MSVA4	160 X 60	193	2.100	700	3,9	Πλέγμα	Φλάντζα	€ 223,00
MSVA5	120 X 60	84	2.450	275	2,5	Πλέγμα	Φλάντζα	€ 96,00
MSVA6	108 X 50	42	1.660	155	1,4	Πλέγμα	Φλάντζα	€ 89,00
MSVA7	85 X 40	33	2.355	80	1,1	Πλέγμα	Φλάντζα	€ 74,00

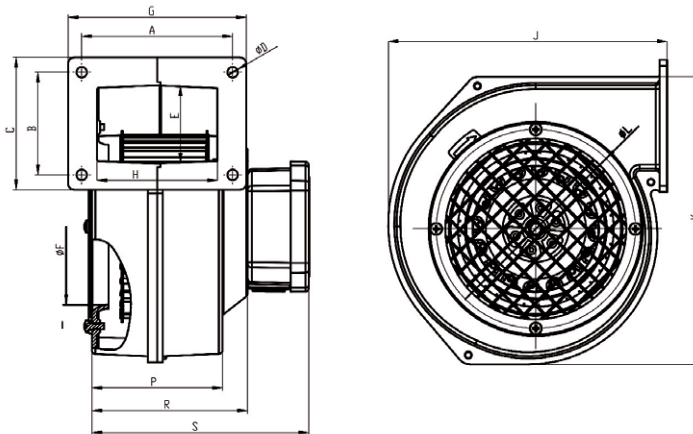

Dimensions (mm)

Type	A	B	C	D	E	F	G	H	J	K	L	P	R	S
MSVA1	123	84	125	6,5	78	110	154	79	197	203	144,5	100	110	151
MSVA4	114	105	120	8	90	117,5	130	93,5	229	248	128	100	-	135
MSVA5	99	67,5	88	6,5	49	103,5	118,5	80	190	184	132	87	104	145
MSVA6	96	66	83	6,5	50	87	115	76	159	183	118	82	-	122
MSVA7	66	58	68	5,5	42	63	76	56	117,5	127,5	84	80	-	120

