

Certified F400 Fans Inside the Hazardous Area BOX RLF F400 Series

BOX RLF F400:

- Box manufactured in galvanised steel sheet.
- Circular inlet flange.
- Backward impeller with self-cleaning system, direct coupling motor.
- Standard asynchronous squirrel-cage motor with IP-55 protection and Class H insulation type F400 2h.
- Manufactured with standard voltages: 230/400V 50Hz in three phase motors up to 3kW, and 400/690V 50Hz for higher powers.
- Exchangeable pannels.
- Open drive.
- Official homologation by the European laboratory APPLUS according to EN 12101-3:2002, EN 12101-3:2002/AC:2005. Certification Nr: 0370-CPR-0582.



BOX RLFX (F400+ATEX):

ATEX II3G.

Under request:

Double skin insulation.



Applications:

Designed for inline installation, they are suitable for:

Air renewal in buildings and industries.

Maximum working temperature: 60°C.

Removing smoke in case of fire. The motor inside the hazardous area (400°C/2 h).

Technical Characteristics BOX RLF Series 400V 4T						
Type	Power (kW)	RPM	Air Flow (m ³ /h)	Sound db (A)	Weight (Kg)	Price
BOX RLF 400 T4 0,75kW	0,75	1.415	4.960	50	115	€ 5.263,00
BOX RLF 450 T4 1,1kW	1,1	1.430	6.580	55	142	€ 5.385,00
BOX RLF 500 T4 1,5kW	1,5	1.435	8.390	60	147	€ 5.463,00
BOX RLF 560 T4 2,2kW	2,2	1.455	12.850	62	187	€ 6.061,00
BOX RLF 630 T4 5,5kW	5,5	1.455	19.180	66	198	€ 9.379,00
BOX RLF 710 T4 7,5kW	7,5	1.455	21.350	75	263	€10.393,00
BOX RLF 800 T4 15kW	15	1.455	32.250	83	339	€14.661,00

Τεχνικά Χαρακτηριστικά BOX RLF 400V 6T						
Type	Power (kW)	RPM	Air Flow (m ³ /h)	Sound db (A)	Weight (Kg)	Price
BOX RLF 400 T6 0,55kW	0,55	920	2.770	40	115	€ 5.263,00
BOX RLF 450 T6 0,55kW	0,55	920	4.370	45	141	€ 5.408,00
BOX RLF 500 T6 0,55kW	0,55	920	5.590	50	146	€ 5.737,00
BOX RLF 560 T6 0,75kW	0,75	920	8.130	52	176	€ 5.962,00
BOX RLF 630 T6 1,5kW	1,5	960	12.710	42	218	€ 6.609,00
BOX RLF 710 T6 2,2kW	2,2	960	16.560	46	273	€ 8.347,00
BOX RLF 800 T6 4kW	4	945	20.950	48	339	€10.234,00

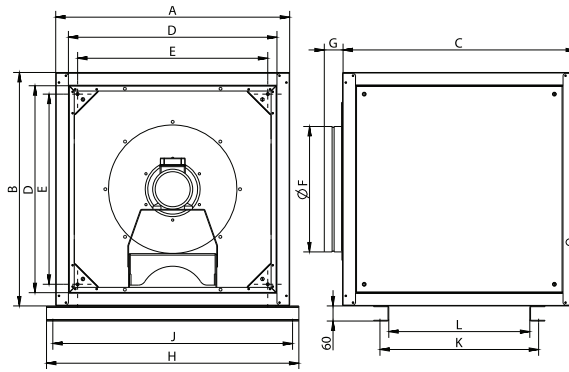

Dimensions BOX RLF Series

Type	A	B	C	D	E	G	H	J	K	L	ØF
BOX RLF 400 T4 0,75kW	800	800	800	696	628,5	74	1002	952	628,5	558,5	398
BOX RLF 400 T6 0,55kW	800	800	800	696	628,5	74	1002	952	628,5	558,5	398
BOX RLF 450 T4 1,1kW	800	800	800	696	628,5	74	1002	952	628,5	558,5	448
BOX RLF 450 T6 0,55kW	800	800	800	696	628,5	74	1002	952	628,5	558,5	448
BOX RLF 500 T4 1,5kW	925	925	925	821	753	74	1127	1077	753	683	498
BOX RLF 500 T6 0,55kW	925	925	925	821	753	74	1127	1077	753	683	498
BOX RLF 560 T4 2,2kW	925	925	925	821	753	74	1127	1077	753	683	548
BOX RLF 560 T6 0,75kW	925	925	925	821	753	74	1127	1077	753	683	548
BOX RLF 630 T4 5,5kW	1000	1000	1000	892	828	74	1203	1153	828	758	628
BOX RLF 630 T6 1,5kW	1000	1000	1000	892	828	74	1203	1153	828	758	628
BOX RLF 710 T4 7,5kW	1000	1000	1000	892	828	74	1203	1153	828	758	698
BOX RLF 710 T6 2,2kW	1000	1000	1000	892	828	74	1203	1153	828	758	698
BOX RLF 800 T4 15kW	1060	1060	1060	952	887	74	1262	1212	887	817	798
BOX RLF 800 T6 4kW	1060	1060	1060	952	887	74	1262	1212	887	817	798

- 1 BOX RLF 400 T4 0,75kW
- 2 BOX RLF 450 T4 1,1kW
- 3 BOX RLF 500 T4 1,5kW
- 4 BOX RLF 560 T4 2,2kW
- 5 BOX RLF 630 T4 5,5kW
- 6 BOX RLF 710 T4 7,5kW
- 7 BOX RLF 800 T4 15kW

- 1 BOX RLF 400 T6 0,55kW
- 2 BOX RLF 450 T6 0,55kW
- 3 BOX RLF 500 T6 0,55kW
- 4 BOX RLF 560 T6 0,75kW
- 5 BOX RLF 630 T6 1,5kW
- 6 BOX RLF 710 T6 2,2kW
- 7 BOX RLF 800 T6 4kW

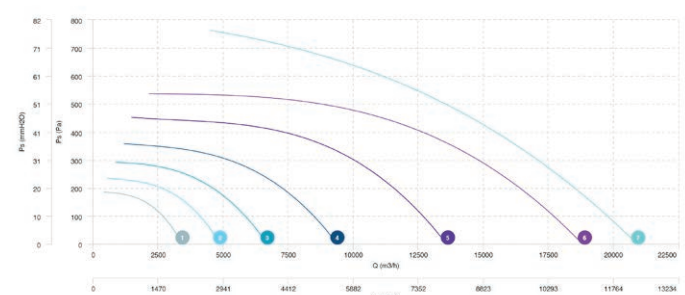
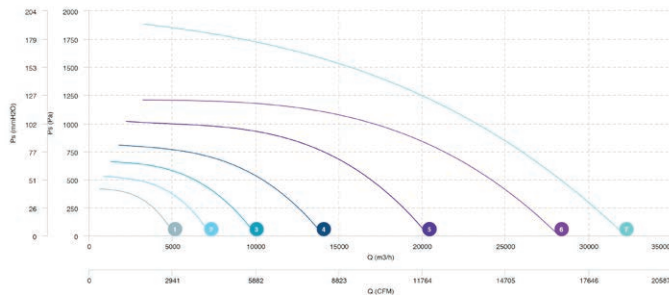

- 1 BOX RLF 500 T4/T8 1,5/0,3kW
- 2 BOX RLF 560 T4/T8 2,2/0,45kW
- 3 BOX RLF 630 T4/T8 5,5/1,1kW
- 4 BOX RLF 710 T4/T8 7,5/1,5kW

- 1 BOX RLF 500 T4/T8 1,5/0,3kW
- 2 BOX RLF 560 T4/T8 2,2/0,45kW
- 3 BOX RLF 630 T4/T8 5,5/1,1kW
- 4 BOX RLF 710 T4/T8 7,5/1,5kW

