



Belt Driven Axial Fans HH Series

- Long cased fan.
- Transmission ball bearings set inside a sealed box manufactured in steel or cast aluminium. Ball bearings permanently greased.
- Cast aluminium impeller with variable pitch angle in origin.
- Polyester powder finishing coat.
- Standard asynchronous squirrel-cage motor with IP-55 protection and Class F insulation. Manufactured with standard voltages: 230/400V 50Hz in three phase motors, up to 4kW and 400/690V 50Hz for higher powers.
- Inspection door located on the lower part of the housing.

Applications:

Air renewal in buildings and industries.

Extraction of hot air up to 110°C.

Maximum working temperature: carried air: 110°C, ambient 60°C.

Under request: Supply impeller (air direction from impeller to motor),
Reversible impeller.
Polyamide impeller.
60Hz fans and special voltages.
2 speed motors.
Hot-dipped galvanised or stainless steel housing.

Technical Characteristics HH Series						
Type	Power (kW)	Στροφέξ (RPM)	Air Flow (m ³ /h)	Sound db (A)	Weight (Kg)	Price
HH 35 T2 0,55kW	0,55	2.800	4.100	64	22	€ 1227,00
HH 35 T4 0,12kW	0,12	1.400	3.150	48	20	€ 1175,00
HH 45 T4 0,37kW	0,37	1.400	6.290	49	36	€ 1284,00
HH 56 T4 0,55kW	0,55	1.400	8.680	56	36	€ 1472,00
HH 56 T4 0,75kW	0,75	1.390	10.940	56	36	€ 1658,00
HH 56 T4 1,1kW	1,10	1.400	12.040	56	39	€ 1739,00
HH 63 T4 1,1kW	1,10	1.400	14.010	56	59	€ 1887,00
HH 71 T4 1,1kW	1,10	1.400	15.970	70	74	€ 1978,00
HH 71 T4 1,5kW	1,50	1.400	18.980	62	77	€ 2026,00
HH 90 T4 3kW	3,00	1.430	29.940	77	113	€ 4125,00
HH 90 T4 5,5kW	5,50	1.440	32.510	78	132	€ 4782,00



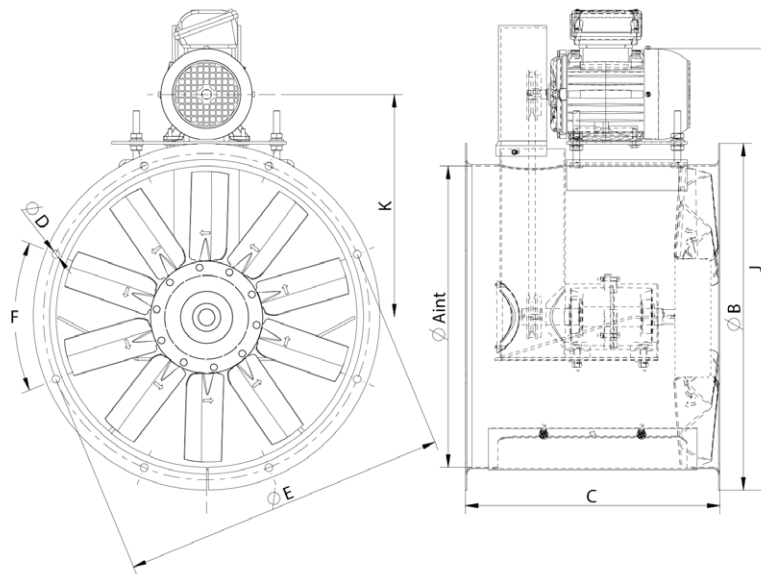

Dimensions Series HH

Type	A	B	C	D	E	F	J max	K max
HH 35 T2 0,55kW	360	420	390,00	10	395	8x45°	540	254
HH 35 T4 0,12kW	360	420	390,00	12	395	8x45°	540	254
HH 45 T4 0,37kW	460	530	390,00	12	500	8x45°	720	355
HH 56 T4 0,55kW	560	650	390,00	12	620	12x30°	858	406
HH 56 T4 0,75kW	560	650	390,00	12	620	12x30°	858	406
HH 56 T4 1,1kW	560	650	390,00	12	620	12x30°	858	406
HH 63 T4 1,1kW	630	720	450,00	12	690	12x30°	950	430
HH 71 T4 1,1kW	715	800	450,00	12	770	16x22,5°	975	478
HH 71 T4 1,5kW	715	800	450,00	12	770	16x22,5°	975	478
HH 90 T4 3kW	905	1002,5	550,00	12	970	16x22,5°	1320	652
HH 90 T4 5,5kW	905	1002	550,00	12	970	16x22,5°	1320	652

1 HH 35 T2 0,55kW

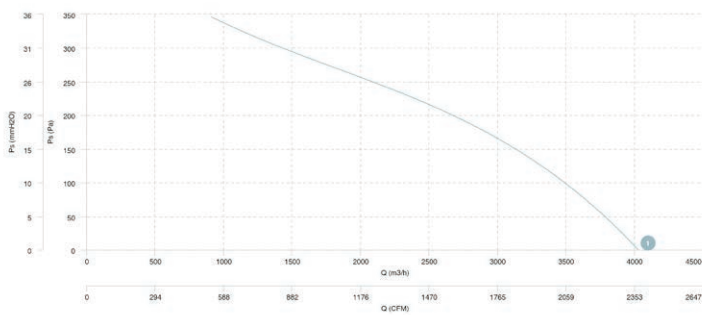

2 HH 45 T4 0,37kW 3 HH 56 T4 0,55kW 4 HH 56 T4 0,75kW
 5 HH 56 T4 1,1kW 6 HH 63 T4 1,1kW 7 HH 71 T4 1,1kW 8 HH 71 T4 1,5kW
 9 HH 90 T4 3kW 10 HH 90 T4 5,5kW

