



Application: Suitable for large halls, greenhouses, pig farms, warehouses, industrial installations, parkings etc.

Axial Fans W Series 1400 RPM

- Excellent quality axial fans with frame.
- High quality 4 pole motor with bearings from the German Factory ebm-papst.
- **IP 44, IP 54.**
- **Class F, B.**
- Thermal protection: All motors are fitted with internal thermal protection (Klixon) to avoid overheating.
- Fans include protection guard.
- Speed controllable.
- Aluminum or plastic gravity Grills available for all fan models.

W4E Series 1400 RPM 230 V

Type	∅ (mm)	Power (W)	Air flow (m ³ /h)	RPM	Amperage (A)	Price
W4E - 250	250	45	1.015	1350	0.22	€ 218,00
W4E - 300	300	70	1.860	1310	0.65	€ 261,00
W4E - 350	350	165	3.305	1340	0.73	€ 286,00
W4E - 400	400	160	4.235	1430	0.73	€ 337,00
W4E - 450	450	490	7.070	1310	2.10	€ 460,00
W4E - 500	500	680	8.905	1380	2.25	€ 526,00
W4E - 560	560	1090	11.690	1370	3.81	€ 579,00

W4D Series 1400 RPM 400 V

Type	∅ (mm)	Power (W)	Air flow (m ³ /h)	RPM	Amperage (A)	Price
W4D - 300	300	68	1.705	1350	0.13	€ 261,00
W4D - 350	350	170	3.320	1400	0.36	€ 286,00
W4D - 400	400	190	4.000	1450	0.44	€ 337,00
W4D - 450	450	480	7.080	1400	0.88	€ 460,00
W4D - 500	500	710	9.030	1395	1.25	€ 532,00
W4D - 560	560	1.100	11.970	1400	1.98	€ 579,00

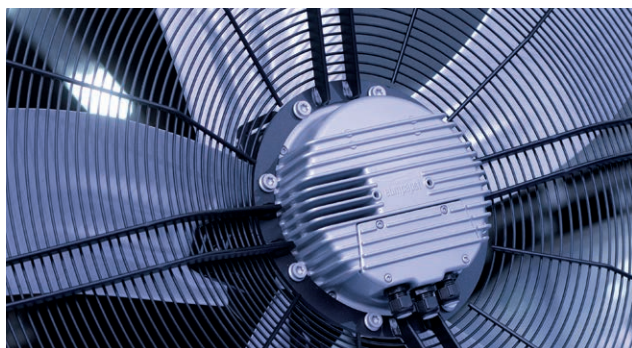

- Airflow direction from motor to impeller (blowing).
- **On request:**
- Airflow direction from impeller to motor (sucking).
- With energy-saving motor. This especially applies to devices with a high duty cycle, such as air-conditioning and refrigeration systems.
- Contact our technical department for more information .

Accessories



AK 20 speed controller



VK Series gravity grilles

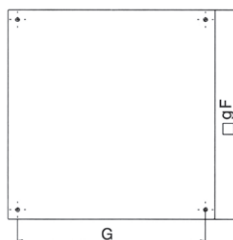
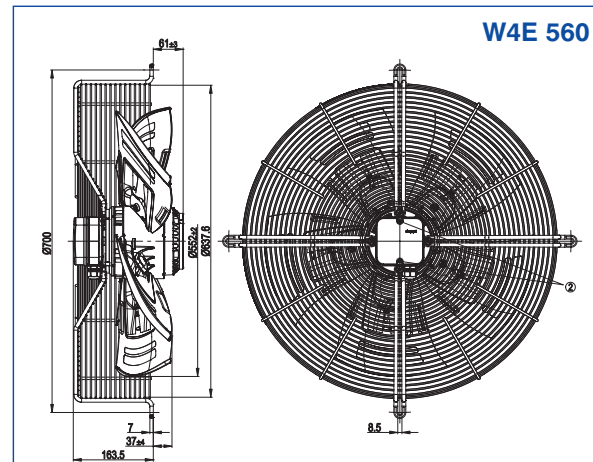
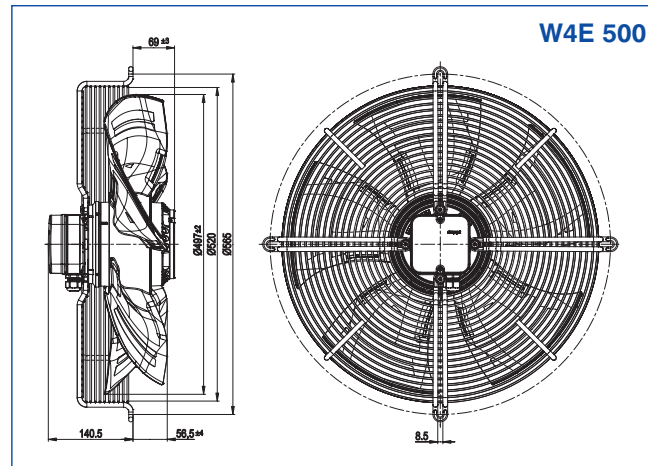
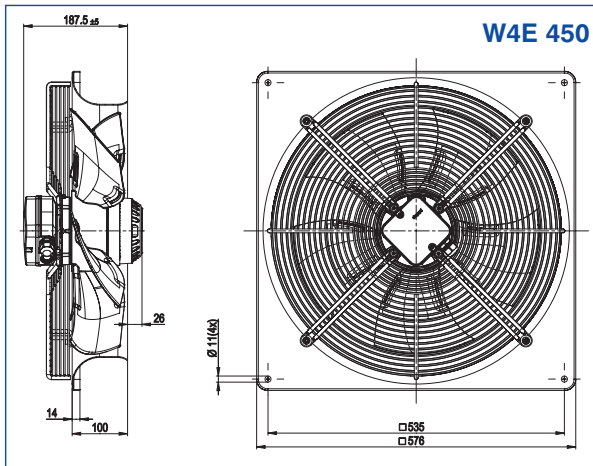
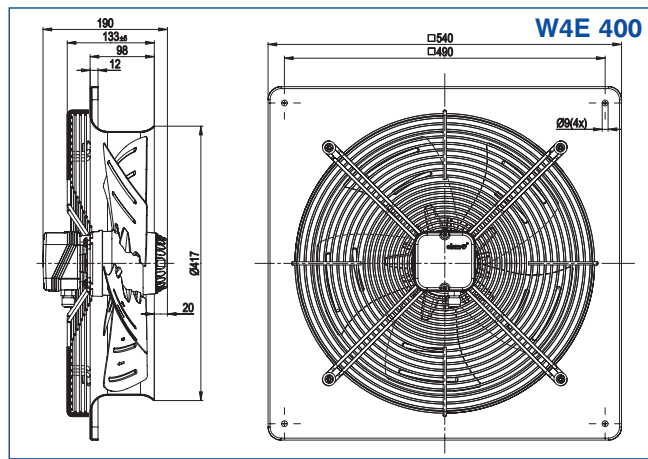
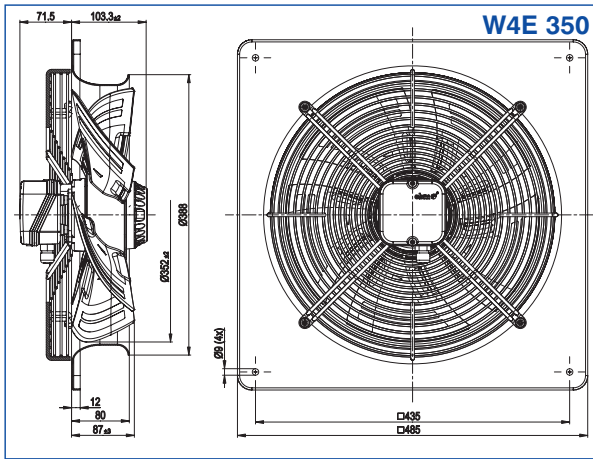
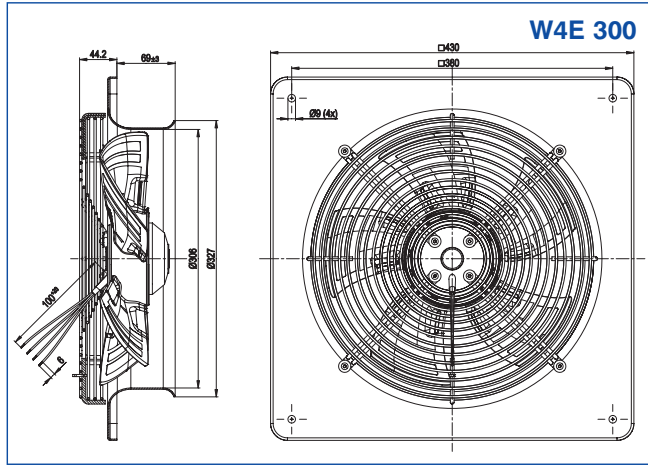
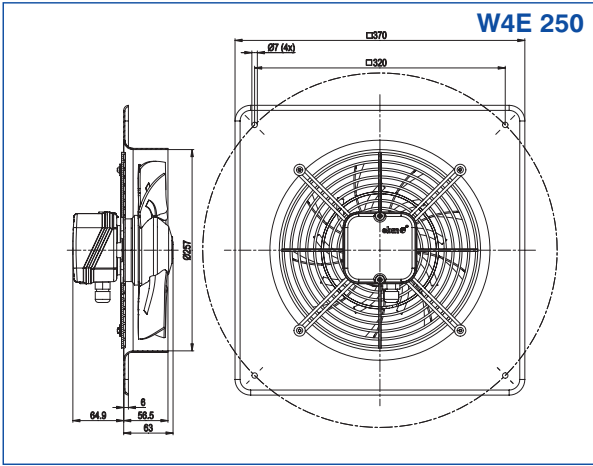

Frame Dimensions		
∅ (mm)	qF (mm)	G (mm)
560	725	675
500	655	615
450	575	535
400	540	490
350	485	435
300	430	380
250	370	320

W4 1400 RPM Dimensions

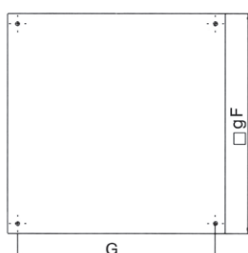
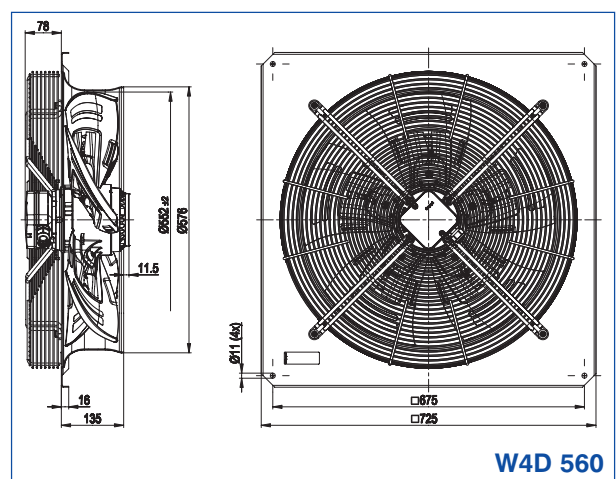
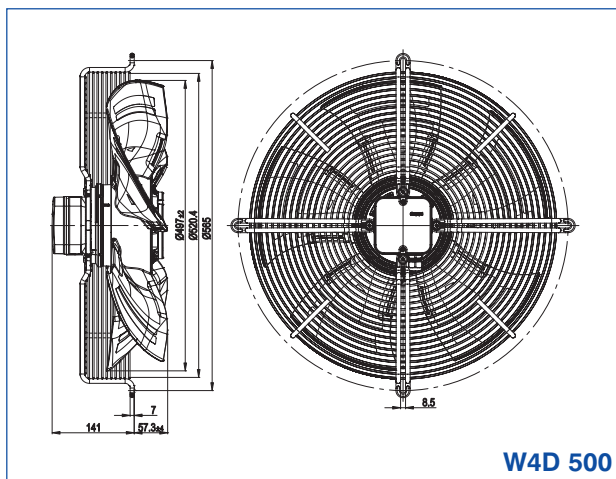
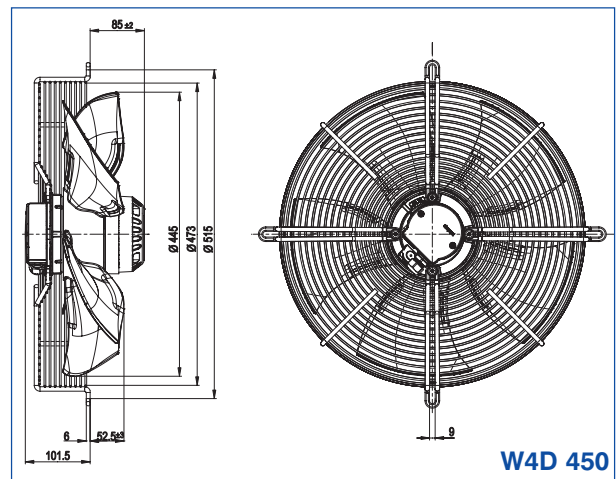
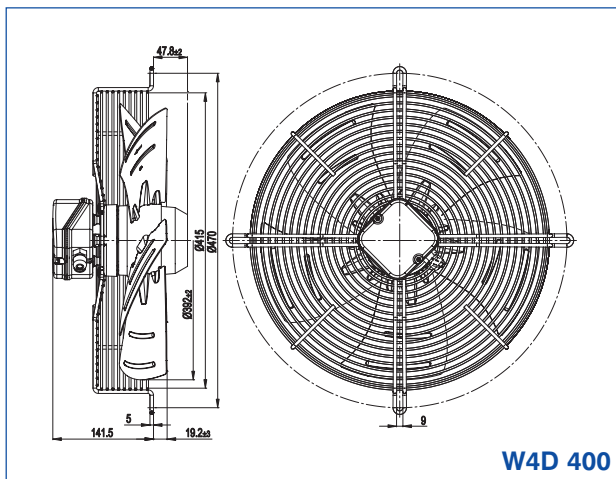
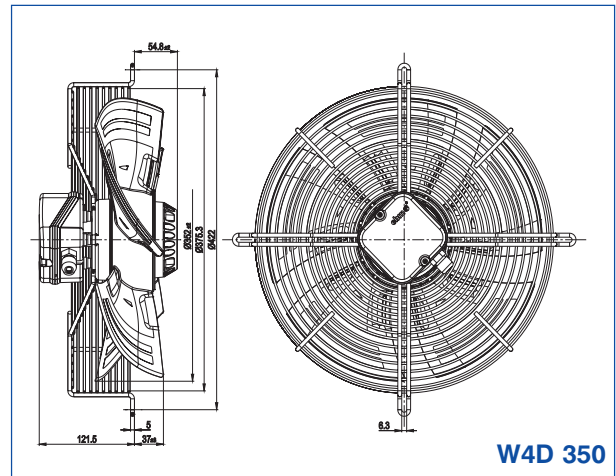
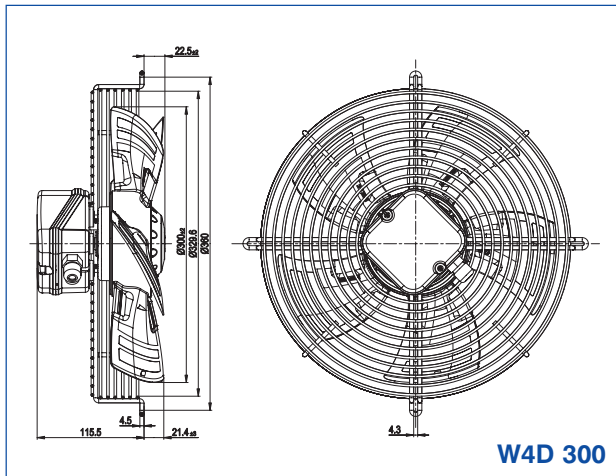

Frame Dimensions		
∅ (mm)	qF (mm)	G (mm)
560	725	675
500	655	615
450	575	535
400	540	490
350	485	435
300	430	380
250	370	320



W4 1400 RPM Series Performance Curves

