

900 RPM & 1400 RPM 3 Speed Double Inlet centrifugal Fans (Direct Drive) DDM Series

- Direct driven centrifugal fans of DDM range with forward curved impeller directly mounted on the external rotor motor are the ideal solution for your applications in the HVAC business.
- Made of galvanised sheet steel.
- External rotor motor with intergrated thermal protector.
- Impeller with forward curved blades of galvanised steel plate.
- Available in various models.
- Fan models suitable for 60 Hz supply are available.

Under request:

Fan mounting inside a Fan Section (F/S).

Optionally any special construction in F/S such as: Inlet necks, rain protection outlet grid etc.

Additional improved double walled insulation etc.

With integrated sealed external rotor motor, with ball bearing instead of pillow block seating, with IP 55 protection and IP 56 protection electrical connection box.

Technical Characteristics DDM 900 RPM / 230V 3 Speed

Type	Power (W)	Voltage (V)	Air Flow (m ³ /h)			Fan Price*	Fan Section Dimensions F/S	Price Asembled F/S
			1 speed	2 speed	3 speed			
DDM 10/8 280	280	230	1.800	2.500	3.300	⌘	60 x 60 x 60	⌘
DDM 10/10 280	280	230	1.800	2.500	3.500	⌘	60 x 60 x 60	⌘
DDM 12/12 500	500	230	3.000	3.750	4.500	⌘	60 x 60 x 60	⌘

Technical Characteristics DDM 1400 RPM / 230V 3 Speed

Type	Power (W)	Voltage (V)	Παροχή (m ³ /h)			Fan Price*	Fan Section Dimensions F/S	Price Asembled F/S
			1 speed	2 speed	3 speed			
DDM 7/7 147	147	230	1.100	1.300	1.700	⌘	50 x 50 x 50	⌘
DDM 9/7 350	350	230	1.150	1.800	2.500	⌘	60 x 60 x 60	⌘
DDM 9/9 350	350	230	1.250	1.900	2.700	⌘	60 x 60 x 60	⌘

* Fan Mounting Base Included

Accessories



3 Speed Switch



Protection Net



Sound Barriers for Rectangular Duct Systems

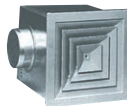

Ventilation & Air Conditioning Plenums



Vents



Air Filters



Axial Fan Heaters With Electric Coils

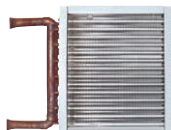

Hot Water Coils



Tubular Air Electric Coils With Fins



Wall Mounting Set



Air Ducts



Connection Necks

Double Inlet Centrifugal Fans

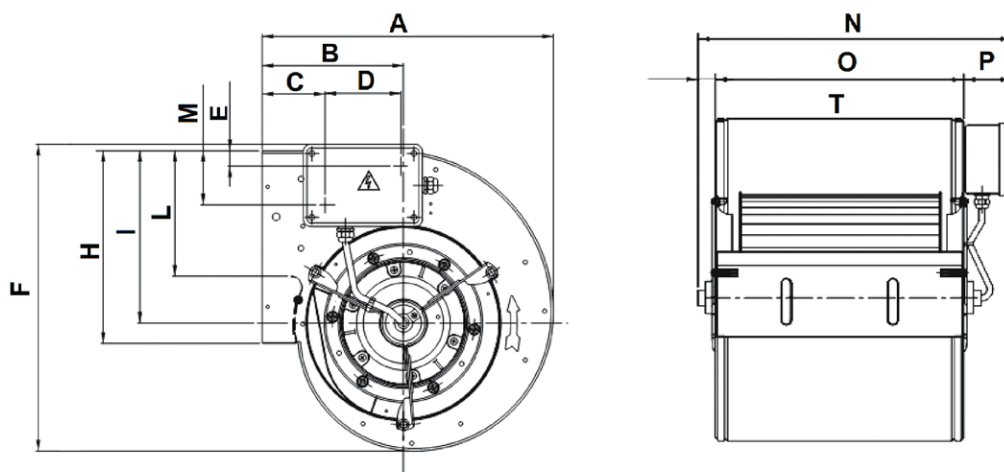

Dimensions DDM 6 3V (mm)

Type	A	B	C	D	E	F	H	I	L	M	N	O	P	T
DDM 9/9 280	378,5	185	127	82	29,5	387	262,6	215,5	159,6	71,5	377	298	58	21
DDM 10/8 280	424,5	203	153	82	34,5	443	289,6	249,5	178,6	76,5	360,5	265	58	37,5
DDM 10/10 280	424,5	203	153	82	34,5	443	289,6	249,5	178,6	76,5	399	331	58	10
DDM 12/12 500	490,5	230	196	82	39	521	341,8	294,5	213,8	81	453	395	58	-

Dimensions DDM 4 3V (mm)

Type	A	B	C	D	E	F	H	I	L	M	N	O	P	T
DDM 7/7 147	315,5	153	68	82	16,5	332	208,6	186,5	135,6	58,5	325	232	58	35
DDM 9/7 350	378,5	185	127	82	29,5	387	262,6	215,5	159,6	71,5	354	232	58	54
DDM 9/9 350	378,5	185	127	82	29,5	387	262,6	215,5	159,6	71,5	377	298	58	21



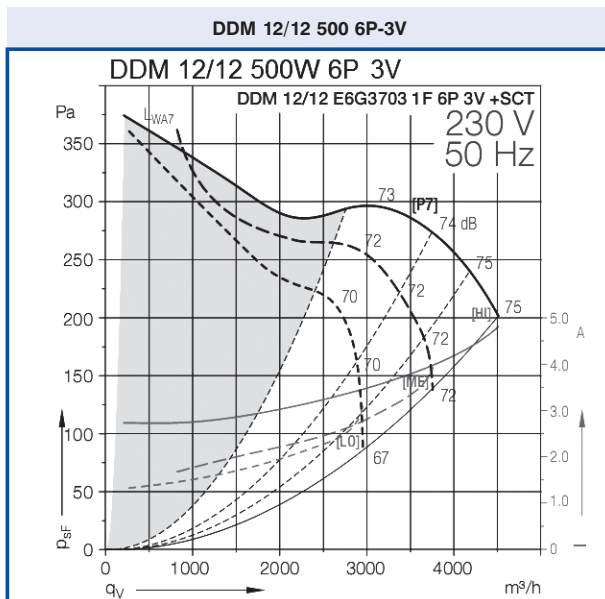
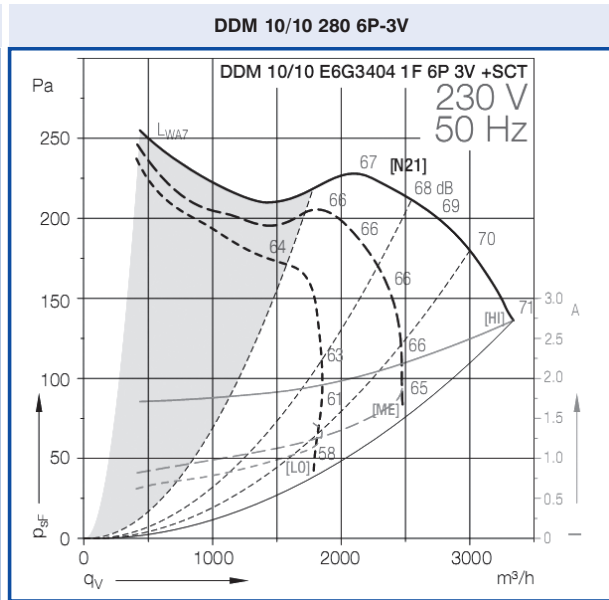
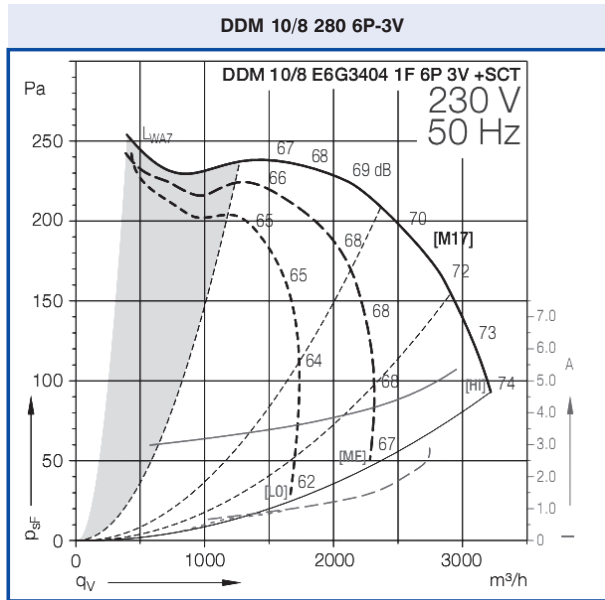

Double Inlet Centrifugal Fans

